

# CUSTOM FOR YOUR NEEDS

Custom pre-fabricated  
walk-ins



[NORBEC.COM](http://NORBEC.COM)

**NORBEC™**  
Norbec Systems Inc.

# Specializing in custom manufacturing, Norbec has earned a solid reputation as a solution finder for the production of cold rooms, freezers and storage lines.

## Norbec's products provide superior quality and exceptional durability.

- Services and Customer Relationship
- Innovation
- Quality
- Continuous Improvement

## Solutions tailored to your projects.

- Restaurants
- Hotels
- Institutions
- Supermarkets & Convenience Stores
- Food processing plants
- Laboratories
- Controlled Atmosphere Rooms

### FLEXIBILITY

Multiple configurations are available: coolers, freezers, combos, refrigerated or dry storage. Solutions are tailored to any needs to allow the maximization of any space.



Two supermarket hinged doors with an aluminium door frame accompanied by a set of swinging doors.

Norbec walk-ins are manufactured according to exact specifications to assure the highest quality, performance and space optimization for all types of projects no matter the complexity.

# WALK-INS

Norbec walk-ins are made of polyurethane core panels incorporated with highly resistant camlocks foamed into place which stand the test of time in any situation.

These walk-ins are highly flexible meeting a wide range of room configurations including ones with non conventional angles. The use of high-quality materials, which is a standard at Norbec, ensures performance as well as increased durability. The panel joints used along with the camlocks provide a water and vapor proof seal required for all types of environments. The elimination of thermal bridges results in efficient insulation which leads to reduced energy costs. Norbec walk-ins are energy efficient as well as quick and easy to install.

## Walk-in Sizes

- Offered in multiple elegant finishes
- Immune to water pressure washing and cleaning products
- Resistant against surface marks and corrosion

- Sizes: custom to any needs
- Height: up to 18'
- Thickness: 3", 4", & 5"
- R-Value of the panel:

Freezer	Cooler
<b>3:</b> R23	<b>3:</b> R20.5
<b>4:</b> R31	<b>4:</b> R27
<b>5:</b> R38.5	<b>5:</b> R33

## Profiles and Finishes

Norbec offers a wide variety of colors and finishes to suit all projects. A silkline profile or smooth profile is offered along with the option of having embossed steel if desired. Default panels are offered in white pre-painted galvanized steel in 26 gauge.

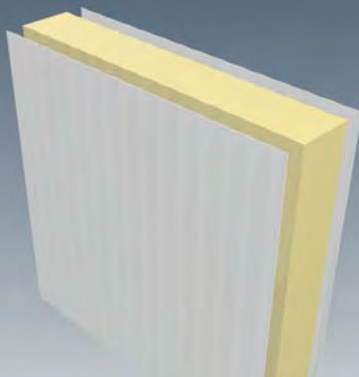

White Silkline finish, exclusive to Norbec, which reduces the surface variations inherent in thin sheet steel

## Steel Options

- White, 26 or 24 gauge
- Black, 26 gauge, Silkline profile
- Galvanized, 26 gauge, stucco embossed finish
- Stainless #4, 22 gauge
- Advantica, 24 gauge, smooth only
- Other colours available on request

## Floors

Norbec's floor designs take into account various contextual applications as well as the load requirements. The materials used in the flooring provide a safe work environment, solidity for the products and shelves placed atop, as well as adding to its durability.

- 18 gauge minimum Galvanized Steel
- Polyurethane Core Panels
- 1" floor spacers for better air ventilation and reduced risk of condensation.
- May support various weight loads.

To be noted : no rolling load allowed.



## Floor Options

Several types of floors are available depending on load requirements

- Reinforcement materials (1/2 or 3/4 plywood)
- Non-slip tread plates (1/8-3/16-1/4)
- Floor spacers of different thicknesses are available for better air ventilation
- Interior & exterior ramps
- 1"-2" cement boards (on-site installation)

## Finishes

- 18 gauge Stainless Steel #2B
- 18 or 16 gauge Galvanized Steel
- 0.100" Smooth Aluminum

# DOORS

The performance of a cold room begins with the design of the door. Norbec continuously innovates its line of doors to offer lasting products and promote energy efficiency. In addition to providing an enhanced waterproof seal, the doors are designed to withstand daily activities throughout the years.

## Choice Of Doors

- Hinged Doors
- Sliding Doors
- Blast Freezer Doors

- Resistant
- Superior sealing
- Heavy duty
- Easy to integrate within the panels

## Other Options

- Glass Door
- Electric Doors
- Service Doors
- Swinging Doors

Norbec offers a wide range of doors providing both flexibility and sturdiness, designed for different applications.

A thermal break is incorporated to the doors to limit the transfer of temperature which causes condensation and in return ice buildup. The design of the frame integrated to the panel provides an aesthetic finish and allows for simple and effective cleaning, while the reinforcements guarantee increased resistance and durability. Moreover, a groove created for the heating wire makes it more accessible when in need of replacement.



Steel hinged flush door in white finish

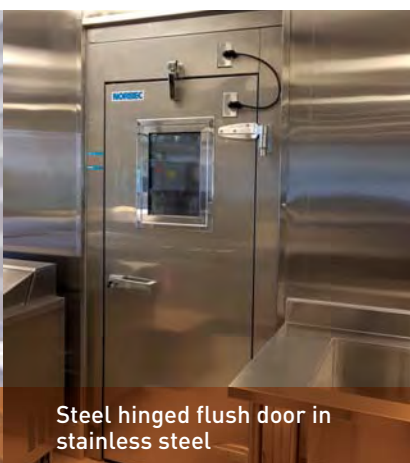

Steel hinged flush door in stainless steel



Glass doors

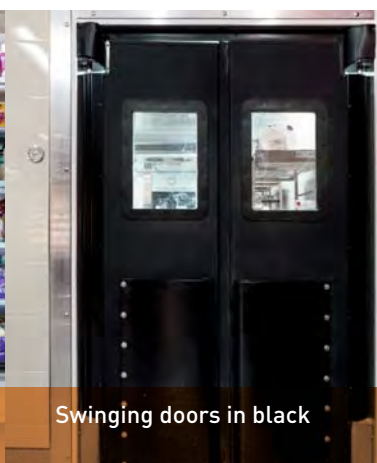

Swinging doors in black

# ACCESSORIES

Maximize the value of any projects by adding from our wide range of accessories.

- Windows for doors (standard size of 15'' x 20'')
- Windows for walls (custom size)
- Protection kickplates
- Bumpers to protect wall surfaces
- Foot pedals for hands free access **a must have!**
- Lights or fluorescent LEDs
- Motion Sensors
- Digital or Analog Thermometers
- Alarm Annunciators (Module I3 only)
- Door closers
- Shelves
- Curtains
- Enclosure panel



Contact Norbec to learn about the complete range of accessories and options offered for all cold rooms projects.

## NovaFlo

In some environments, especially kitchens, the presence of moisture caused by dishwashers can lead to a risk of mold. To prevent this unfortunate situation, Norbec developed a solution to reduce the risk of mold accumulation around the cold rooms. The NovaFlo technology is a ventilation system installed above the cold room which allows a constant airflow around the room. The use of forced air guarantees sufficient temperature in the concealed space at all times preventing condensation buildup.

- 1** Optional access hatches are placed around the edges of the cold room ceiling to allow a visual inspection of the space.
- 2** The junction is sealed between the bulkheads in order to provide sufficient air pressure.
- 3** Powerful fans are positioned in strategic locations on the room's ceiling in order to allow optimal air circulation

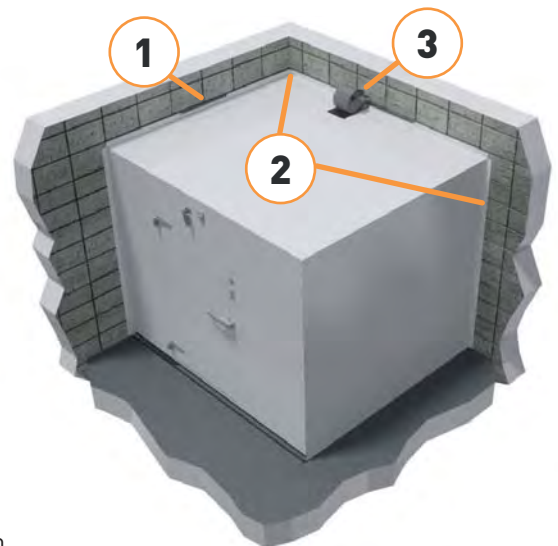

# MODULES AND CONTROLS

## Refrigeration Intelliref V2 Control System

An integrated electronic module designed to simplify refrigeration controls by combining the functions of a thermostat and defrost timeclock.

### FOR COOLERS :



INTELLIREF V2

### FOR FREEZERS :



INTELLIREF V2  
LOW TEMPERATURE +  
DEFROST

### ADVANTAGES

- Saves on electrical and installation costs
- Factory mounting allows a consistent assembly where all components are concealed in the evaporator
- Each unit is checked in factory, which ensures better quality control

### OPTIONAL FEATURES :

#### LDA :

- Sends notifications by text message or email to critical responders such as refrigeration contractors or restaurant owners regarding status and locations of the alarm
- Troubleshooting can be done remotely to prevent the loss of food
- Results in saving on expensive service calls

#### Data logging:

- Records temperature variations
- Allows refrigeration contractors to establish quick and precise problem diagnosis by consulting historical data
- Compliant with HACCP requirements

### CARACTERISTICS

Module is pre-wired in factory and then installed on the evaporator by the refrigeration contractor.



## I3

The I3 is an alarm control and temperature display module

### CHARACTERISTICS

- Integrated in the door frame
- Temperature display
- Lighting control
- Alarms
  - High and low temperature
  - Open door
  - Panic situation

### OPTIONS

- Panic button
- External alarm signal with dry contact
- Three-way lighting control
- Alarm indicating NovaFlo fan default

**Norbec provides peace of mind turnkey solutions for all cold rooms, accessories, refrigeration and installation needs. Norbec's experienced teams are present throughout every step of a project, no matter its complexity.**

## INSTALLATION

Norbec handles the coordination of the installation to allow you to save time and ensure the best quality of installation at a fair price.

### A NETWORK YOU CAN COUNT ON!

- National Network
- No-hassle Solution
- 24/7
- High installation standards
- Measurement Service

## REFRIGERATION

Norbec offers a wide variety of refrigeration systems for time optimization, reliable product efficiency and the best environment for food.

Evaporators can either be conventional or a central installation.

### COMPRESSOR

- Air or water-cooled
- Hermetic, semi-hermetic or Scroll
- Indoor or outdoor use
- One piece unit (pro3)
- Parallel system
- Custom-made

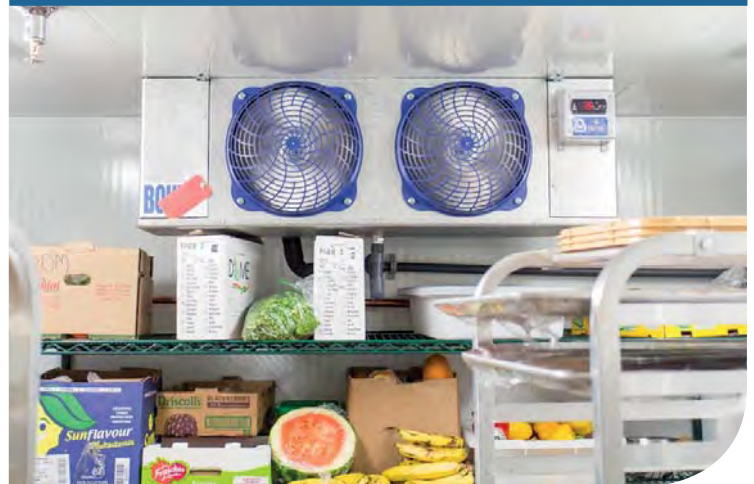

## SAFETY - HEALTH-COMPLIANT - ENERGY SAVING

Norbec attaches great importance to providing products that meet the food service requirements and energy standards. Our research and development team is continuously up-to-date on all standards and codes in order to offer tailored products for all projects.



Norbec can provide, if necessary, walls and floors that follow health code requirements according to project needs.

### Warranty

Norbec has a 5-year warranty policy for panels and a 1-year warranty policy for materials and parts. Our after sales team is always prepared and available to respond to any need you may have.



Systèmes Norbec Inc.

**Norbec Systems Inc.**

97 rue de Vaudreuil, Boucherville,  
Québec J4B 1K7  
1 877 667 2321

For more information about Norbec products,  
please visit **[norbec.com](https://shop.norbec.com)**

To order your parts online or find out more related  
information, visit **<https://shop.norbec.com/magasin/en/>**.

**NORBEC.COM**

