

NORBEC™

Norbec Systems Inc.

| Installation Guide



97, rue de Vaudreuil,

Boucherville (Québec) J4B 1K7

Tel. : (450) 449-1499

Fax. : (450) 641-4657

Toll Free: 1 877 667-2321

****ATTENTION****

**PLEASE READ PRIOR TO
INSTALLATION AND START UP**

TABLE OF CONTENT		
Reception of Product		3
1	Important	3
2	Steps to follow at delivery in case of short shipment or damaged product	3
3	Steps to follow if concealed damage is found	4
4	Steps to follow at carrier's inspection	4
5	Steps to follow after inspection	4
6	Steps to follow before installation	4
Installation Instructions		5
7	Walk-in placement	5
8	Surface preparation	6
9	Panel installation	6
10	Electricity	8
11	Refrigeration	8
12	Options	8
13	PL 1750 Hinged Door Installation Detail	9

14	OPERATING INSTRUCTIONS MODULE IM4	9
15	INTELLIREFV2 COOLER CONTROLS AND SETTINGS	10

RECEPTION OF PRODUCT

1. IMPORTANT:

- 1.1 Keep all proof of delivery
 - Bills of lading
 - Shipping lists
 - Lists of crates and panels
 - Carrier paperwork

2. STEPS TO FOLLOW AT DELIVERY IN CASE OF SHORT SHIPMENT OR DAMAGED PRODUCT:

- 2.1 Verify the count
 - 2.1.1
 - Make sure you have same number of crates or boxes as the number indicated on your ship list coupon.
 - If there is a discrepancy, duly note it on the carrier paperwork.
 - Ask carrier to indicate it on your copy.
- 2.2 Examine the state of each crate or box and make sure nothing is damaged
 - 2.2.1
 - If damages are visible, note it on the shipping papers and ask carrier to note it on your copy.
 - If it appears that the material is damaged within the truck, insist that it be opened right away.
 - The carrier and receiver must inspect it.
 - All concealed damages must be noted on the ship list.
 - Make sure to keep your copy.
- 2.3 Immediately after delivery, open all boxes and inspect them for concealed damage
 - 2.3.1
 - Even though the driver has already left, all boxes should immediately be opened and all the contents inspected for possible concealed damage.

3. STEPS TO FOLLOW IF CONCEALED DAMAGE IS FOUND:

- 3.1 Hold damaged items
 - 3.1.1
 - All damaged items along with their crating, wrapping and any related material must be kept at delivery point until inspection is done by carrier's inspector.
- 3.2 Contact carrier to signal damaged goods and to request an inspection
 - 3.2.1
 - The call must be made immediately after damage is found.
 - Under no circumstance should the call exceed 15 days from original product reception.
 - No claim for concealed damage will be accepted after 15 days.
- 3.3 Confirm damage call to carrier by a written statement
 - 3.3.1
 - For your protection you should always follow the call to the carrier with a written notification.
 - Make sure to keep a copy of your letter.

4. STEPS TO FOLLOW AT CARRIER'S INSPECTION:

- 4.1 Make sure that damaged items are in reception/delivery zone
 - 4.1.1
 - Make sure that no damaged items were moved from the original reception zone where the problem was originally found. Allow inspector to check damaged items, crates or boxes and bill of lading.
 - All original carrier reception documents will be required to support the claim.
- 4.2 When inspection is report complete, read thoroughly before signing
 - 4.2.1
 - If you do not accept inspector's conclusions, do not sign the inspection report.
 - Please make sure that the inspector indicates complete replacement of damaged goods on his report.
 - A new item can only be ordered if report states « REPLACEMENT ».

5. STEPS TO FOLLOW AFTER INSPECTION :

- 5.1 Store damaged products in a secure location at site
 - 5.1.1 Even if inspection is completed, the damaged items must not be used or eliminated without written permission from carrier.
- 5.2 Do not return damaged products to the carrier
 - 5.2.1 The return of any merchandise cannot be done without the authorization of the supplier.
- 5.3 Keep carrier receipt if they pick up the items
 - 5.3.1 If the merchandise is recuperated by the carrier, ensure you have the carrier's receipt at time of pick up.

6. STEPS TO FOLLOW BEFORE INSTALLATION :

- 6.1 Make sure that all material is received according to shipping list

NORBEC
 Systèmes Norbec Inc.
 97 De Vaudreuil
 Boucherville Québec J4B 1K7
 Canada

Phone: 450-449-1499
 Fax: 450-641-4657
 Page 1 of 6

Sales Order #

Packing Slip

Bill to Contact: Phone: Fax:	Ship to Contact: Phone: Fax:	
PO: Ship date:	Ship Via: Packing Slip:	FOB: Sales Person:

Line	Planned Qty	Ship Qty	Backorder	Part Number	Rev.	Description
2	1,00 un/ea	1,00	0,00	0902-00001		Ensemble porte & cadre sur mesure
3	1,00 un/ea	1,00	0,00	0705-00002		Rideau lamelle - Congélateur - Montage mural
4	3,00 un/ea	3,00	0,00	0606-00007	01	Assemblage de trappe témoin pour cavité d'air
5	3,00 un/ea	3,00	0,00	0606-00001	01	Assemblage ventilateur PSC

6.1.1 The shipping list is in a transparent envelope stack to the side of your crate or pallet.

6.1.2 If items are missing, contact Norbec's customer service.

INSTALLATION INSTRUCTIONS

7. WALK-IN PLACEMENT

- 7.1 Determine exact walk-in location with customer.
- 7.2
 - Trace exterior placement of walls as indicated on your assembly drawing.
 - When tracing, it is important to respect the minimal spacing (2") between walk-in and building walls.
- 7.3 Make sure there are no interferences within the area where the walk-in will be located (width, length, height).

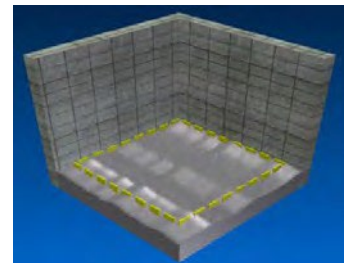

8. SURFACE PREPARATION



IMPORTANT

- Make sure surfaces are clean and dry.
- Make sure installation surface is levelled (Max ¼" at 10').

- 8.1 For rooms with insulated floors, adjustment of installation surface must be made by pouring self leveling concrete

- 8.2
- In case of a floorless room, the levelling adjustment must be within floor screeds supplied by Norbec.
 - Installation of screed may be done directly on the floor following instruction details supplied with the cold room.
- 8.3 If it is impossible to level the floor, make sure all panels are installed following the same plane.

9. PANEL INSTALLATION :



IMPORTANT

- Sharp edges may be present on some panels. Gloves should be worn when installing panels.
- Allow 12 hours before using your cold-room.

9.1 GÉNÉRAL

- 9.1.1 A two- person crew is preferable to install a walk-in. Some panel may be too long or heavy to be handled alone
- 9.1.3 Before installing a panel, make sure the plastic protective adhesive film is removed.
- 9.1.4 The installation system requires the use of a hexagonal key supplied by Norbec.
- 9.1.5
- When installing panels, it is preferable not to tighten all cam-locks of the panel when positioning it.
 - Only tighten one per axis. This will allow panel adjustment.
 - Finish tightening of all cam-locks when all panels are in place.
- 9.1.6 Except if otherwise indicated on assembly drawings, Norbec panels are designed to have cam-lock fasteners on the inside of the walk-in.

9.2 BASE

- 9.2.1 For room with insulated floor, install floor panel (numbered B...) following the assembly drawing supplied with your installation kit. As mentioned on 8.2 , floor leveling is critical.
- 9.2.2
- For a floorless room, apply construction adhesive (supplied by Norbec) on the floor as indicated on the assembly drawing. Make sure that there are no air pockets between the screed and the floor.
 - As per details, fix the screed to the floor with appropriate fasteners and follow the required spacing.
 - Screed junctions must be filled with silicone to ensure air tightness.
 - Cut screeds at a 45-degree angle at corners.

9.3 WALLS

- 9.3.1 For room with insulated floor, install wall panel in the floor panel grooves designed to receive wall panel tongue.
- 9.3.2 For floorless room, make sure each panel is leveled or follow the same angle. If the shimming of the panel tends to be too high, apply spray foam insulation between the screed and floor to fill the gap.
- 9.3.3
- Position first wall panel (numbered M...).
 - You should start by a corner panel.

- Second panel will fit perpendicularly into first panel, this will give strength and stability to the assembly and facilitate the wall installation.
- 9.3.4 If final assembly is a two-room combination, make sure to start with the shared wall of the combination walk-in.
- 9.3.5 Continue assembly of all panels as per assembly drawing.

9.4 CEILING

- 9.4.1 Install ceiling panels (numbered T...) following assembly drawing.
- 9.4.2
- If plan indicates ceiling suspension points, you should install suspension at each panel as they are installed.
 - For suspension installation details, refer to details on assembly drawing.
- 9.5.1 Once all panels are in place, tighten all cam-lock fasteners.

9.5 FINITION

- 9.5.2 Install the caps on top of all cam-lock openings. Use white caps on white surfaces and grey caps on grey surfaces.
- 9.5.3
- Apply silicone at all panel junctions (ceiling, floor, walls), inside and outside where possible.
 - Silicone must also be applied along all floor screeds.
 - Silicone may be required at other areas; if so it will be indicated on assembly drawings.
- 9.5.4 In the case of an NSF approved room, step 9.5.3 is not required.
- 9.5.5 Complete the form titled **Quality Control for Walk-In and Refrigeration Installation** and send it back as indicated.

GUIDELINES FOR SEILING WALK-IN FREEZERS AND COOLERS LIGHT

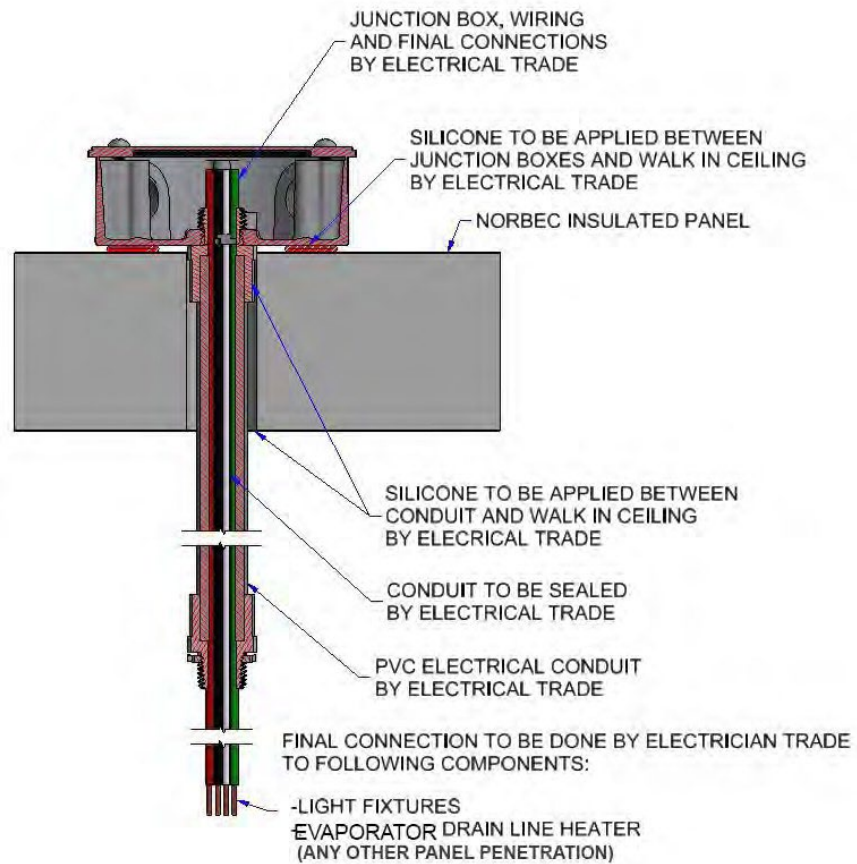

10. ELECTRICITY:

- 10.1.1 A certified electrician must make the electrical connection(s) between walk-in and building electrical systems.
- 10.1.2 The lights may be shipped uninstalled on ceiling panels. This detail may apply to the majority of panel penetrations.
- 10.1.3 If an intelligence module is supplied or a part must be replaced, please refer to **Appendix**.

11. REFRIGERATION:

- 11.1.1 All types of refrigeration system must be installed by a certified refrigeration specialist.

12. OPTIONS:

If other options have been requested, the installation must be made as per details on the assembly drawing.



PL1750 HINGED DOOR INSTALLATION DETAIL

Step 1.

Cut the door opening in the panels. Allow a clearance of 1-1/2" in width and 1" in height to the finished opening dimension shown on the installation drawing.

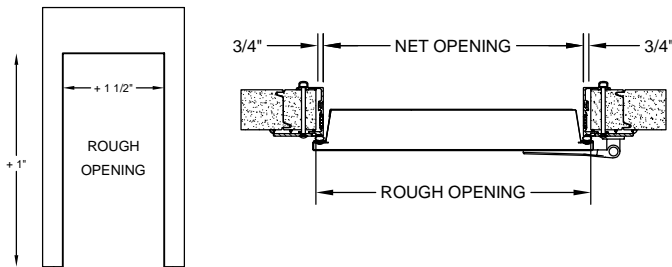

Step 3.

Then slide the back frame pieces into place, secure temporarily with clamps and level the door head, then the hinge-side jamb and finally the opposite jamb. Ensure that top and side back frame are well aligned without any gaps.

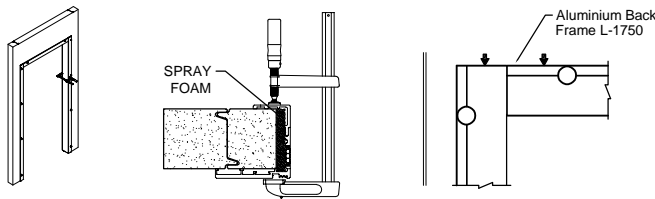

Step 5.

Secure the frame with the carriage bolts, washers and nuts supplied with the kit. (Be careful not to over-tighten and emboss the aluminium back frame.)

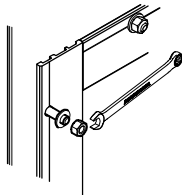

Step 7.

On the inside, install door frame stabilizing angle on each side of opening using the anchors supplied in the kit.

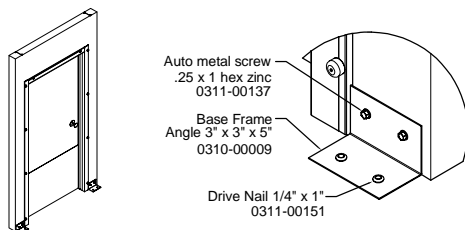

Step 2.

Insert the door and front frame assembly into the previously created opening and hold in place to spray urethane from the inside between the panel opening and front frame.

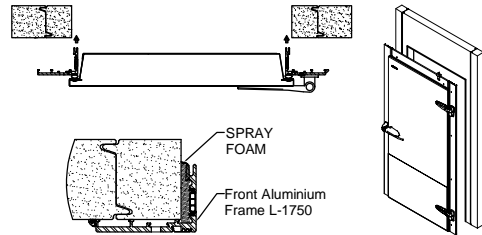

Step 4.

Using the pre-drilled holes in the frame, drill holes through the panel using a 7/16" drill bit.

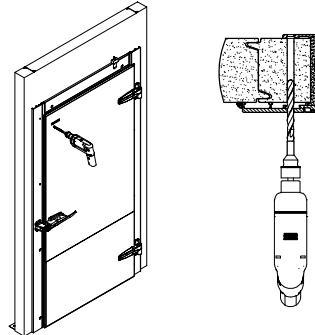

Step 6.

Cut off bolts ensuring excess of 1 x thread from the nut on the rear side with a cut-off saw, apply finishing vinyl caps.

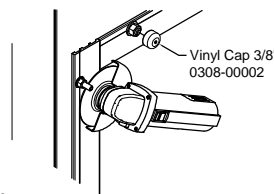

Step 8.

Apply a bead of silicone around the perimeter of front and rear frame.

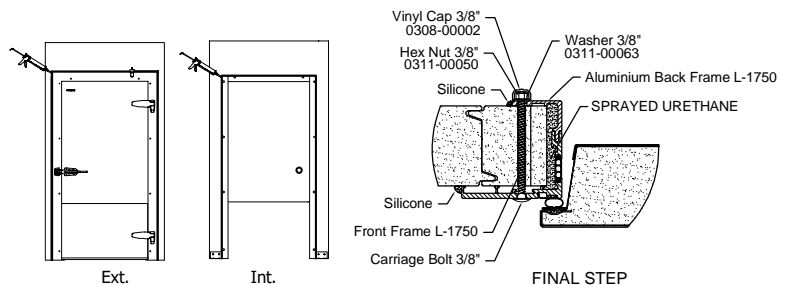

YOUR RESPONSIBILITY WHEN RECEIVING FREIGHT

SAVE ALL DELIVERY RECEIPTS

1 - STEPS TO TAKE AT TIME OF DELIVERY TO PROTECT AGAINST LOSS OR DAMAGE

A. VERIFY COUNT –

Make sure you are receiving as many cartons as are listed on the delivery. If any shortage is discovered, note exactly how many cartons are short on the carrier's delivery receipt and have the driver note the shortage on your copy.

B. CAREFULLY EXAMINE EACH CARTON FOR DAMAGE –

If damage is visible, so note this fact on the delivery receipt and have the driver clearly note that fact on your copy. If carton has appearance that contents inside may possibly be damaged, insist that it be opened right at that time, and both you and the driver should make joint inspection of the contents. Any concealed damage discovered should like wise be noted on the delivery receipt and on your copy. Be sure to retain your copy.

C. IMMEDIATELY AFTER DELIVERY, OPEN ALL CARTONS AND INSPECT FOR CONCEALED DAMAGE –

Even though driver has already left, all cartons should immediately be opened and the contents inspected for possible concealed damage.

2 - STEPS TO TAKE WHEN VISIBLE OR CONCEALED DAMAGE IS DISCOVERED

A. RETAIN DAMAGED ITEMS –

Not only must the damaged items be held at the point where received, but the containers and all inner packing materials must be held until an inspection is made by a carrier inspector.

B. CALL CARRIER TO REPORT DAMAGE AND REQUEST INSPECTION –

The call should be placed immediately upon discovery of the damage, but under no circumstances should it be put off longer than 15 days after delivery. Failure to report concealed damage within this 15 day period will almost certainly result in the carrier denying your claim.

C. CONFIRM CALL IN WRITING –

Although this is not a mandatory requirement, for your own protection in establishing the fact the carrier was notified within the 15 day period, we strongly recommend that all calls be confirmed in writing. Be sure to retain a copy of your letter.

3 - STEPS TO TAKE WHEN CARRIER MAKE INSPECTION OF DAMAGED ITEMS

A. HAVE DAMAGED ITEMS IN RECEIVING AREA –

Make certain the damaged items have not been moved from the receiving area prior to discovery of the damage. Allow inspector to inspect damaged items, cartons, inner packing materials and freight bill. Be sure to retain your delivery receipt – it will be needed as a supporting document when claim is filed.

B. AFTER INSPECTOR FILLS OUT INSPECTION REPORT, CAREFULLY –READ IT BEFORE SIGNING

If you do not agree with any facts or conclusions made by the inspector on the report, do not sign it. Unless repairs will be completely satisfactory, be sure the inspector requests replacement **on the inspection report**. A new item can be ordered only if the inspection report specifies "REPLACE".

4 - STEPS TO TAKE AFTER INSPECTION HAS BEEN MADE

A. CONTINUE TO RETAIN DAMAGED MERCHANDISE –

Even though inspection has been completed, damaged items cannot be used or disposed of without written permission from the carrier.

B. DO NOT RETURN DAMAGED ITEMS TO SHIPPER –

Return of such items should not be made without written authorization of the supplier.

C. SECURE RECEIPT FROM CARRIER IF DAMAGED ITEMS ARE PICKED UP FOR SALVAGE –

If your surrender damaged merchandise to a carrier for salvage because it is valueless to you, be sure to secure a receipt from the driver when it is picked up and retain that receipt.



Object: [Operating instructions module IM4](#)

Operating and Configuring Instructions

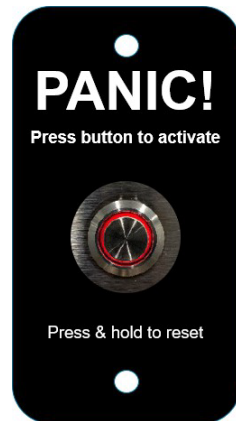
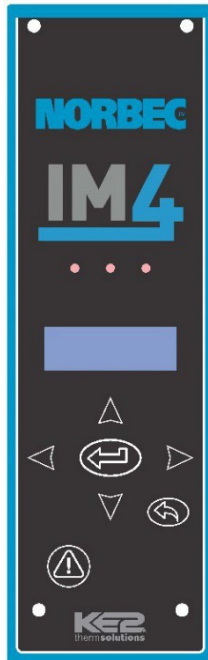

1. Up
2. Down
3. Left
4. Right
5. Enter
6. Back
7. Mute Button

Description for Each Feature

Temperature Monitoring and Display

The unit displays the temperature in degrees Celsius (°C) [adjustable, see *Parameter Descriptions*].

Should one or more alarms be present, the display will show the alarms first. If there are no active alarm, the screen displays only the variables.

Lighting Control

The lighting is controlled by detecting the opening of the door, which will turn the lights ON and the closing door will initiate a 5-minute countdown [adjustable, see *Parameter Descriptions*]; 30 seconds before the end of the delay, the lights will blink to indicate that the lights are about to turn OFF. This is to warn anyone inside to move to the exit door before the lights go OFF.

Temperature Alarms

These alarms are activated 45 minutes [adjustable, see *Parameter Descriptions*] after reaching the pre-recorded High and Low temperature levels. An audible alarm (about 95 dB) from the keypad will then occur. The display will show the message HIGH MONITOR TEMP2 ALARM or LOW MONITOR TEMP2 ALARM, [see *Alarm Message Descriptions*]. The dry contact (normally closed) from the alarm relay will activate the external alarm signal (low voltage).

The High and Low temperature alarm settings and the activation delay can be modified in the parameter menu.

Door Open Alarm

If the door remains open for more than 15 minutes [adjustable, see *Parameter Descriptions*],

this alarm is triggered and an audible alarm from the keypad will occur. The display will show the message DOOR OPEN ALARM [refer to *Alarm Message Descriptions*]. The dry contact (normally closed) from the alarm relay will activate the external alarm signal (low voltage).

Panic Alarm

This alarm can be triggered when the backlit push button is pressed and held, located inside, near the door opening. When pressing this button, the lights will turn ON and an audible alarm from the keypad will occur and the dry contact (normally closed) from the alarm relay will activate the external alarm signal (low voltage). The display will also show the message HELP. Once this alarm is triggered, the mute button will not work. The push button must be pressed and held for 3 seconds to deactivate the alarm.

Muting an Alarm

Pressing the "Silent" button  on the keyboard during an alarm will mute the audible signal but the associated alarm message will remain until the alarm condition disappears.

Battery Backup

The 9-Volt battery holder is located inside the controller. In normal condition, this battery should maintain the temperature display and the alarm messages in operation during power outages. The dry contact (normally closed) from the alarm relay will activate the external alarm signal (low voltage).

The rechargeable battery is positioned upside down in the base. It is necessary to reposition it as shown in the diagram below during the first on-site installation.

1. Switch off the module power supply.
2. Unscrew the screws holding the keyboard
3. Lift the keyboard to access the back of the module.
4. Install the battery.

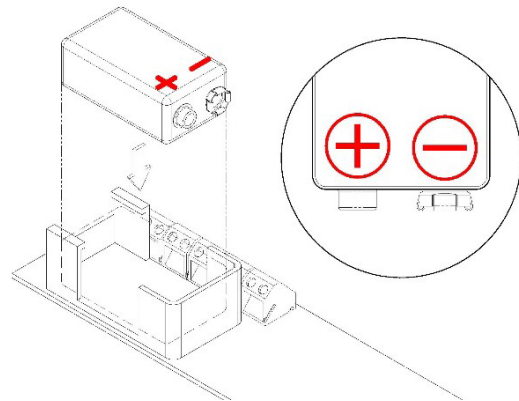

Three-Way Switch for Lighting















This option allows controlling lighting through two different doors in automatic mode. You must refer to the IM4 wiring diagrams for the proper electrical connection.

Options

Fan Failure Alarm



When a ventilation system circulates air in concealed spaces around the exterior of walk-in cold rooms, optional sensors can be supplied to monitor the presence of air flow on each blower. With this option, if airflow stops, the system triggers an audible alarm from the keyboard, the dry contact (normally closed) from the alarm relay will activate the external alarm signal (low voltage) and the display will show the message EXT ALARM alternating with the actual temperature.

Parameters Setting

1. Enter the Programming Mode by pressing the  &  and holding for 3 seconds.
The display will show AUX 1 FUNCTION and the green and yellow LED lights will start blinking.
2. Use  or  to scroll through the different configuration parameters.
Press  to display the current value of the parameter.
3. Press  and hold for 3 seconds to change the value.
The yellow and red LEDs will start blinking and the parameter can be adjusted.
Use  or  to scroll through the options.
When the value is a number, a digit starts blinking. Use  or  to change the value of the digit, use  or  to move to the next digit.
4. Press  and hold for 3 seconds to save the change.
5. Press  to return to the Programming Mode.
Repeat steps 2 to 5 to change additional parameter.
Press  3 times to return to the default display.

Parameter Description

Message	MIN VALUE	MAX VALUE	NORBEC DEFAULT VALUE	DESCRIPTION
AUX 1 FUNCTION*	DISABLED	EXTERNAL ALARM	DISABLED	DISABLE / DOOR TEMP / DOOR SWITCH / EXTERNAL ALARM
AUX1 SWITCH STATE*	OPEN	CLOSED	OPEN	State of input for door to be open or external alarm to be active
DOOR TEMP*	-10.0°F	100.0°F	35.0°F	Temperature where heaters are turned on
DOOR TEMP DIFF*	0.1°F	10.0°F	3.0°F	Temperature offset above 'DOOR TEMP' to turn door heater off
HI DOOR ALR OFST*	0.1°F	100.0°F	100.0°F	Temperature offset above 'DOOR TEMP' for high door temperature alarm
LO DOOR ALR OFST*	0.1°F	20.0°F	5.0°F	Temperature offset above 'DOOR TEMP' for low door temperature alarm
DOOR TEMP ALR DLY*	1 minute	1440 minutes	15 minutes	Delay time when door temperature is out of range before setting alarm
DOOR SWITCH STATE	DISABLED	CLOSED	OPEN	State of input for door to be open or disable function (disable, open or closed)
DOOR ALARM DELAY	0 minute	1440 minutes	15 minutes	Time for door to be open before setting door open alarm
LIGHTS OFF DELAY	0 minute	60 minutes	5 minutes	Time after door closes that lights relay is de-energized
AUX 2 FUNCTION	DISABLED	EXTERNAL ALARM	ROOM TEMP	DISABLE / ROOM TEMP / DOOR SWITCH / EXTERNAL ALARM

AUX2 SWITCH STATE	OPEN	CLOSED	OPEN	State of input for door to be open or external alarm to be active
Message	Min Value	Max Value	Norbec Default Value	Description
AUX3 FUNCTION (Fan Failure Alarm)	DISABLED	EXTERNAL ALARM	EXTERNAL ALARM	DISABLE / DOOR TEMP / DOOR SWITCH / EXTERNAL ALARM
AUX3 SWITCH STATE	OPEN		CLOSED	State of input for Aux3: Open / Close
MON TMP2 HI ALRM	-60.0°F	90.0°F	Cooler: 43°F / 6°C Freezer: 10°F / -12°C	If monitor temp2 is above this set point for some time, set high temp2 alarm
MON TMP2 LO ALRM	-60.0°F	90.0°F	Cooler: 32°F / 0°C Freezer: -13°F / -25°C	If monitor temp2 is above this set point for some time, set low temp2 alarm
MON TEMP2 AL DLY	1 minute	1440 minutes	45 minutes	Delay time when temp2 is out of range before setting alarm
<i>MON TMP3 HI ALRM*</i>	<i>-60.0°F</i>	<i>90.0°F</i>	<i>35.0°F</i>	<i>If monitor temp3 is above this set point for some time, set high temp2 alarm</i>
<i>MON TMP3 LO ALRM*</i>	<i>-60.0°F</i>	<i>90.0°F</i>	<i>-10.0°F</i>	<i>If monitor temp3 is above this set point for some time, set low temp2 alarm</i>
<i>MON TEMP3 AL DLY*</i>	<i>1 minute</i>	<i>1440 minutes</i>	<i>15 minutes</i>	<i>Delay time when temp3 is out of range before setting alarm</i>
BUZZER MODE	DISABLED	DOOR ALARM ONLY	ENABLED	Function for buzzer DISABLED, ENABLED, DOOR ALARM ONLY
DISP BRIGHTNESS	1	50	18	Dim or brighten display
<i>ADDRESS*</i>	<i>1</i>	<i>5</i>	<i>5</i>	<i>Modbus Adresse</i>
DISP CLEAR ALARM	—	—	—	Press and hold  for 3 seconds, until display changes, to clear alarm set in combo display
<i>DISP FACTORY RST*</i>	—	—	—	<i>Press and hold  for 3 seconds, until display changes, to change set points to factory defaults</i>
TEMPERATURE UNITS	CELSIUS FAHRENHEIT	—	CELSIUS	Temperature units : Fahrenheit, Celsius

**Disregard for IM4*

Alarm Message Descriptions



Use the  and  buttons to view the active alarms.

Message	Description
ROOM TEMP2 SENSOR ALARM	Temp 2 input is shorted or open.
HIGH MONITOR TEMP2 ALARM	Temp 2 input is above High Temp Alarm offset for longer than High Temp Alarm Delay.
LOW MONITOR TEMP2 ALARM	Temp 2 is below Low Temp Alarm Offset for longer than Low Temp Alarm Delay.
DOOR OPEN ALARM	Door has been open longer than Door Alarm Delay.
EXTERNAL ALARM 1, 2, Or 3	If input is selected as external alarm, and alarm becomes active.

Silencing Buzzer

Once the alarm signal is detected, the buzzer can be muted by pressing the mute button . The alarm message and the dry contact (normally closed) from the alarm relay will activate the external alarm signal (low voltage) will be displayed until the alarm condition is reset.

Display Variables

If there is no alarm active, only the variables will be displayed. Use the  and  buttons to view them.

Variables	Description
TEMP 2 READING	<p>Toggle between TEMP2 and value read by controller, if 'DOOR SWITCH' selected, 'T2 DOOR CLOSED, T2 DOOR OPEN' if 'EXTERNAL ALARM' selected, 'T2 EXT ALARM ACTIVE, T2 NO EXT ALARM</p> <p>The range is -87.7°F to 183.0°F. If there is a sensor failure, value will read 888.8. Will report T2 DOOR CLOSED if reads that door is closed, T2 DOOR OPEN if reads that door is open. Will report T2 EXT ALARM active, T2 NO EXT ALARM if read alarm is inactive ACTIVE if reads that alarm is.</p>
DOOR SWITCH STATE	<p>DOOR CLOSED DOOR OPEN DOOR SWITCH DISABLED</p> <p>Will report "DOOR CLOSED" if reads that door is closed; "DOOR OPEN" if reads that door is open; "DOOR SWITCH DISABLED" if door switch function is disabled.</p>

INTELLIREFV2 COOLER CONTROLS AND SETTINGS

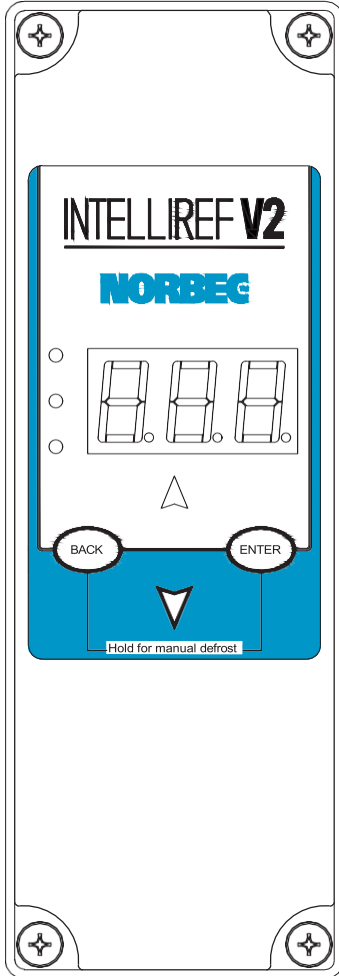

Indicator lights

- Red Blinking - the Real Time Clock battery needs replaced
- Yellow light - non-critical alarm (system running)
- Green light - compressor on
- Green blinking - compressor waiting on timer to start / stop

Access Setpoint mode by pressing and holding the **ENTER** button until tS (temperature setpoint) displays on the screen.

Use the **▲** up and **▼** down arrows to scroll through the available setpoints.

Press **ENTER** to view the current setting.

Use the **▲** up and **▼** to change the setpoint, Press **ENTER** to move between the digits to accelerate the changes.

Press **ENTER** and hold to confirm each setpoint change.

Press **BACK** to escape.

KE2 Temp + Defrost

NORBEC: 0419-00078 (KE2: 20611)

Basic Setpoints

Setpoint	Description	Minimum	Default	Maximum
tS	Temperature Setpoint	-50°F (-45°C)	2 C°	100°F (38°C)
diF	Differential	1°F (1K)	1 C°	30°F (17K)
CSH	Maximum Compressor Starts/Hour	5 (Off)*	6	10
dPd	Defrost Per Day	0	6	12, CUS**
dFt	Defrost Time	0 min	15 min	720 min
Unt	Units for temp display	FAH / CEL	CEL	CEL

* Selecting fewer than 5 compressor starts per hour results in the starts per hour feature being turned off. The compressor will then function on temperature only.

** Selecting CUS (custom) unlocks additional Setpoints. See Advanced Setpoints table.

Service Call Saver - Post Defrost Indicator

To eliminate unnecessary/unwarranted service calls, the KE2 Temp + Defrost alerts the user when it is coming out of a defrost cycle using the onboard display. The display alternates between dEF and the actual temperature measured by the air sensor. This continues until temperature has reached setpoint, or for the amount of time set by dFt (Defrost Time) whichever is shorter.

INTELLIREFV2 FREEZER CONTROLS AND SETTINGS

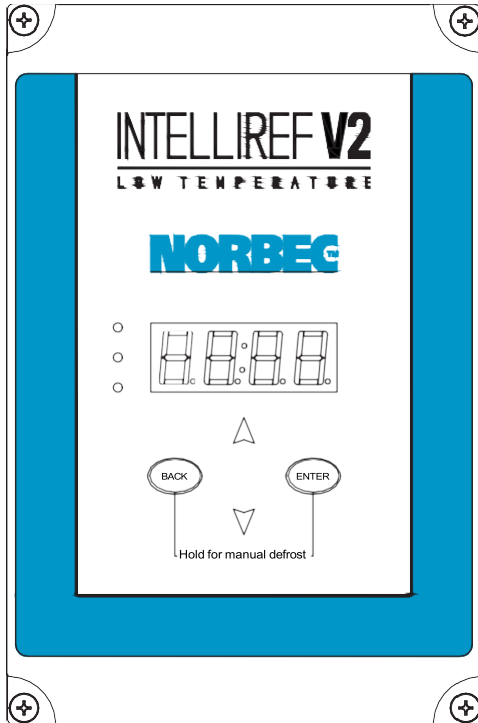

- Indicator lights
- Red Blinking - Basic Menu - not used; Advance Menu - pulsing
 - Yellow light - non-critical alarm (system running)
 - Green light - compressor on
 - Green blinking - compressor waiting on timer to start / stop

Access Setpoint mode by pressing and holding the **ENTER** button until tS (temperature setpoint) displays on the screen.

Use the **▲** up and **▼** down arrows to scroll through the available setpoints.

Press **ENTER** to view the current setting.

Use the **▲** up and **▼** to change the setpoint, Press **ENTER** to move between the digits to accelerate the changes.

Press **ENTER** and hold to confirm each setpoint change.

Press **BACK** to escape.

KE2 Low Temp + Defrost

NORBEC: 0419-00079 (KE2: 20903)

Basic Setpoints

Setpoint	Description	Minimum	Default	Maximum
tS	Temperature Setpoint	-50°F (-45°C)	-18 C°	100°F (38°C)
diF	Differential	1°F (1K)	2 C°	30°F (17K)
CSH	Maximum Compressor Starts/Hour	5 (Off)*	6	10
dtyP	Type of Defrost, Air or Electric	Air	Elec	Elec
dPd	Defrost Per Day	0	4	12, CUS**
dtsP	Defrost Term Temperature Setpoint	-	15 C°	-
dFt	Defrost Time	0 min	45 min	720 min
dnt	Drain Time	0 min	2 min	15 min

* Selecting fewer than 5 compressor starts per hour results in the starts per hour feature being turned off. The compressor will then function on temperature only.

** Selecting CUS (custom) unlocks additional Setpoints. See Advanced Setpoints table.