

NORBEC™

CUSTOM DOORS

TECHNICAL SHEETS





CL-1650

SLIDING DOOR WITH HEAVY DUTY FRAME



The materials used in the manufacture of sliding doors are sturdy and provide superior sealing. Each door is individually designed and manufactured in-house. From designing to manufacturing, the concern for quality is vital in product development.

In addition to providing good insulation properties and enhanced waterproof seal, the doors are designed to withstand daily activities throughout the years. They are manufactured for the most demanding environments (heavy duty usage, high salinity, moisture and strong chemicals). Norbec considers industry regulations such as health standards, energy standards and building standards throughout the entire process.

Over time, Norbec sliding doors have become a standard in the supermarket and food processing industry for their ease of operation, robustness and energy efficiency.

ADVANTAGES OF NORBEC SLIDING DOORS

- ▶ Highly resistant structure
- ▶ Resistant to corrosion and chemicals
- ▶ Ideal for applications that require the use of equipment such as forklifts
- ▶ Recommended for places where space is limited
- ▶ Available with gravity or manual closure (locking option in open position)

DOOR

The door comes equipped with all-aluminum and nylon hardware as well as easy-to-replace EPDM gaskets. It is easy to adjust and opens and closes with minimum effort, thanks to its nylon wheels mounted on sealed precision ball bearings and its nylon stay roller located out of the way under the door. The rail is attached directly to the doorframe. The door is internally reinforced with steel angles for added strength.

FRAME

Made of 1/2" thick L-shaped custom-extruded aluminum, Norbec's unique doorframe is by far the sturdiest in the industry. The standard frame includes a thermal break and for freezer applications a double heater wire is integrated that is seamlessly protected by a removable molding enabling quick and easy replacement. The aluminum surface threshold is welded to the doorframe for added strength. The door frame construction is ideal for retrofitting in existing walls.

DIMENSIONS

Door thickness: 3", 4" or 5"
Width: 36" to 120"
Height: 72" to 120"

Other dimensions available upon request

HARDWARE

RAIL	TROLLEYS (2)	STAY ROLLER	STEAL GUIDE	HANDLES
1/4" thick structural aluminum and 1/2" brackets	4 nylon wheels mounted on sealed precision ball bearings with side guiding	Nylon adjustable eccentric puck on galvanized base, located under the door	Aluminum molded parts that ensure perfect seal when door is closed	Exterior: standard handle Interior: recessed handle

OPTIONAL ACCESSORIES

- ▶ Self-closing gravity system with hold-open and anti-bounce devices (available for 42" to 96" openings)
- ▶ Protection kick plates
 - 18 or 16 gauge galvanized steel
 - 14, 16 or 18 gauge stainless steel # 2B
 - Aluminum tread plate 1/16", 1/8" or 3/16"
- ▶ Security lock system
- ▶ Recessed threshold to be sunk into the concrete slab for freezers. Heater wire is covered by a 3/8" thick aluminum plate
- ▶ Extension of door jamb into concrete slab for superior strength
- ▶ Meat rail opening
- ▶ Door guard made of 3/8" steel angle anchored to the floor
- ▶ Heated door frame
- ▶ Lever handle

Other options available upon request.

INSTALLATION

The frame is designed to be installed in an existing wall. The opening in the wall should be 1 1/2" wider and 1" higher than the clear opening of the door, including clearance for adjustment. The front of the frame must be bolted through the wall with carriage bolts that join the rear of the frame. The frame mounting holes are pre-drilled at the factory. Bolts, nuts, washers and finish caps are supplied with the door. The assembled rail shall be anchored to the doorframe with factory positioned bolts. The stay roller guide shall be anchored to the floor and adjusted as indicated on the layout provided. The door, frame and hardware are all supplied and arrive separately on site. Once installed, adjustments are required to ensure proper operation as indicated in the installation guide. Floor-to-wall angle reinforcements provided shall be added inside to the left and right sides of the doorframe.

TECHNICAL DETAILS

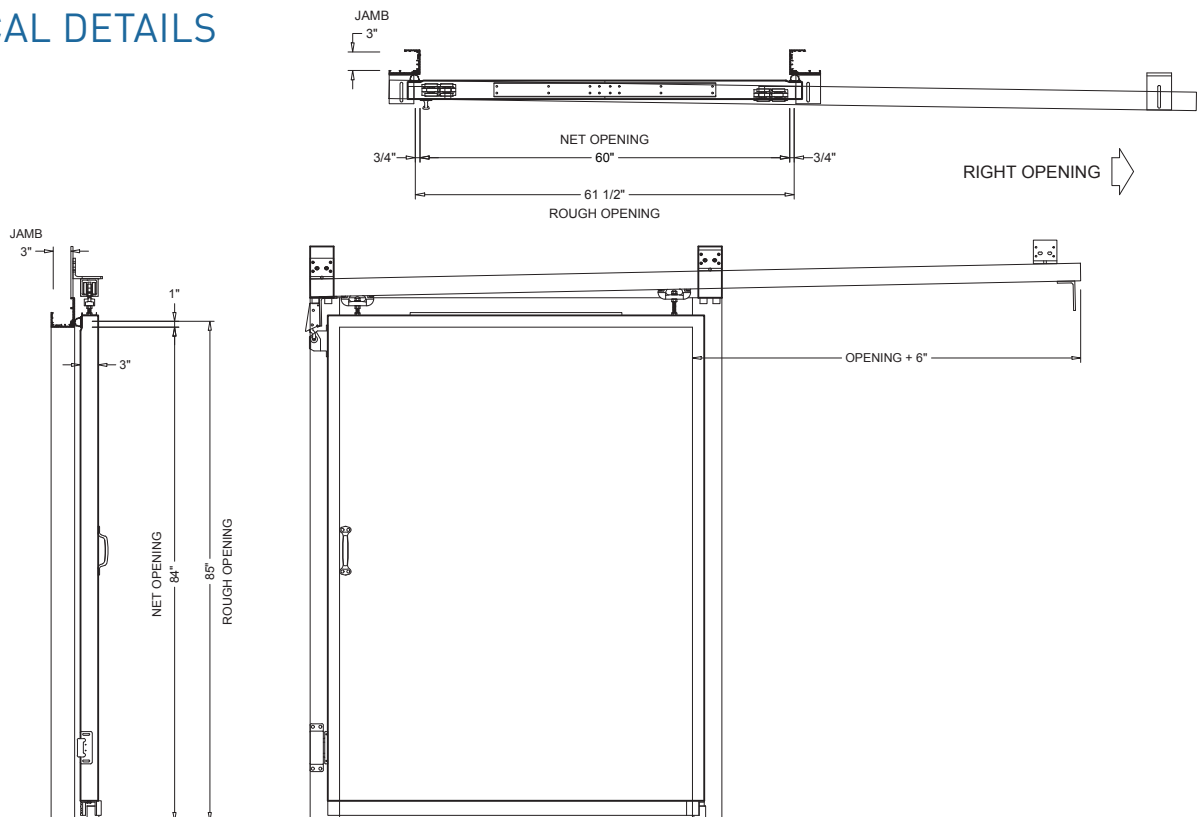



CP-130

SLIDING DOOR WITH HEAVY DUTY FRAME



The materials used in the manufacture of sliding doors are sturdy and provide superior sealing. Each door is individually designed and manufactured in-house. From designing to manufacturing, the concern for quality is vital in product development.

In addition to providing good insulation properties and enhanced waterproof seal, the doors are designed to withstand daily activities throughout the years. They are manufactured for the most demanding environments (heavy duty usage, high salinity, moisture and strong chemicals). Norbec considers industry regulations such as health standards, energy standards and building standards throughout the entire process.

ADVANTAGES OF NORBEC SLIDING DOORS

- ▶ Highly resistant structure
- ▶ Resistant to corrosion and chemicals
- ▶ Ideal for applications that require the use and handling of equipment such as forklifts
- ▶ Recommended for places where space is limited
- ▶ Available with gravity or manual closure (locking option in open position)

DOOR

The door comes equipped with all-aluminum and nylon hardware as well as easy-to-replace EPDM gaskets. It is easy to adjust and opens and closes with minimum effort, thanks to its nylon wheels mounted on sealed precision ball bearings and its nylon stay roller located out of the way under the door. The rail is attached directly to the doorframe, reinforced on the inside with steel plates. The door is internally reinforced with steel angles for added strength.

FRAME

The door is mounted directly to a 47" wide cam-friction panel with a 1/4" aluminum jamb that incorporates a thermal break under the seal and a groove for easily accessible heating wire. All the pre-spun components in the frame are grouped together at a single point of connection.

DIMENSIONS

Door thickness: 3", 4" or 5"
Width: 24" to 42"
Height: 72" to 120"

Other dimensions available upon request

HARDWARE

RAIL	TROLLEYS (2)	STAY ROLLER	STEAL GUIDE	HANDLES
1/4" thick structural aluminum and 1/2" brackets	4 nylon wheels mounted on sealed precision ball bearings with side guiding	Nylon adjustable eccentric puck on galvanized base, located under the door	Aluminum molded parts that ensure perfect seal when door is closed	Exterior: standard handle Interior: recessed handle

OPTIONAL ACCESSORIES

- Kick plates or corner guard on door
 - 18 or 16 gauge galvanized steel
 - 14,16 or 18 gauge stainless steel # 2B
 - Aluminum tread plate 1/16", 1/8" or 3/16"
- Security lock system
- Recessed threshold to be sunk into the concrete slab for freezers. Heater wire is covered by a 3/8" thick aluminum plate
- Door guard made of 3/8" steel angle anchored to the floor
- Heated door frame
- Lever handle

Other options available upon request.

INSTALLATION

The panels are fixed by cam-friction fasteners and the frame is integrated into a panel. An angle of attachment will be added on each side of the frame to the floor, on the inside. The assembled rail shall be anchored to the doorframe with factory positioned bolts. The stay roller guide shall be anchored to the floor and adjusted as indicated on the layout provided. The door, frame and hardware are all supplied and arrive separately on site. Once installed, adjustments are required to ensure proper operation as indicated in the installation guide.

TECHNICAL DETAILS

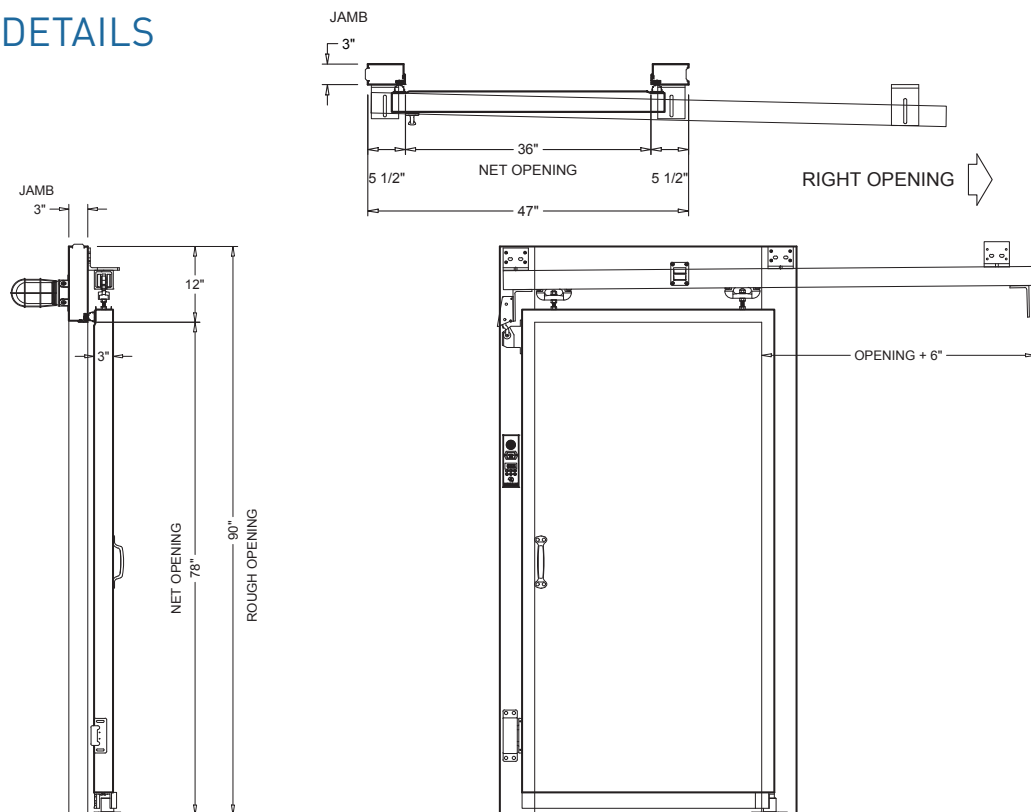



PL-1650

HINGED DOOR



The materials used in the manufacture of hinged doors are sturdy and provide superior sealing. Each door is individually designed and manufactured in-house. From designing to manufacturing, the concern for quality is vital in product development.

In addition to providing good insulation properties and enhanced waterproof seal, the doors are designed to withstand daily activities throughout the years. They are manufactured for the most demanding environments (heavy duty usage, high salinity, moisture and strong chemicals). Norbec considers industry regulations such as health standards, energy standards and building standards throughout the entire process.

ADVANTAGES OF NORBEC HINGED DOORS

- ▶ Highly resistant structure
- ▶ Easy and quick installation
- ▶ Several options available for multiple applications
- ▶ Resistant to corrosion and chemicals
- ▶ Ease of maintenance

DOOR

This offset door is designed so that the outer and inner walls are mechanically assembled to prevent delamination during repeated impacts. Gaskets are easily replaceable in addition of being resistant to grease and detergents. Doors are equipped with galvanized steel reinforcement at the anchor points of the hardware to ensure durability.

FRAME

Constructed from 1/2" thick "L" aluminum profiles, this unique door frame is by far the most robust in the industry. It is provided with a thermal break. The freezer frame is equipped with a heating wire totally integrated in the profile and covered by a molding that facilitates its replacement. The profiled aluminum sill is provided with a double heating wire.

DIMENSIONS

Door thickness: 3", 4" or 5"
Width: 24" to 60"
Height: 72" to 192"

Other dimensions available upon request

HARDWARE

HINGES	HANDLES	INTERIOR PUSH BAR
2 Kason #1245 (for doors under 48") or 2 Kason #1277	Kason #78 brushed chrome	Kason #481 glow-in-the-dark knob

OPTIONS

- > Protection kick plates
 - 18 or 16 gauge galvanized steel
 - 14,16 or 18 gauge stainless steel # 2B
 - Aluminum treadplate 1/16", 1/8" ou 3/16"
- > ST-1000 independent surface threshold for freezers. Heater wire is covered by a 3/8" thick aluminum plate
 - > RT-1000 independent recessed threshold in the concrete slab
 Heater wire is covered by a 3/8" thick aluminum plate
 - > "L" shaped threshold for doors without door broom
 - > Extension of door jamb into concrete slab for more strength
 - > Windows

Other options available upon request.

INSTALLATION

The frame is designed to be installed in an existing wall. The opening in the wall should be 1 1/2" wider and 1" higher than the clear opening of the door, including clearance for adjustment. The front of the frame must be bolted through the wall with carriage bolts that join the rear of the frame. The frame mounting holes are pre-drilled at the factory. Bolts, nuts, washers and finish caps are supplied with the door. Reinforcement angles must be added inside the left and right sides of the door frame.

TECHNICAL DETAILS

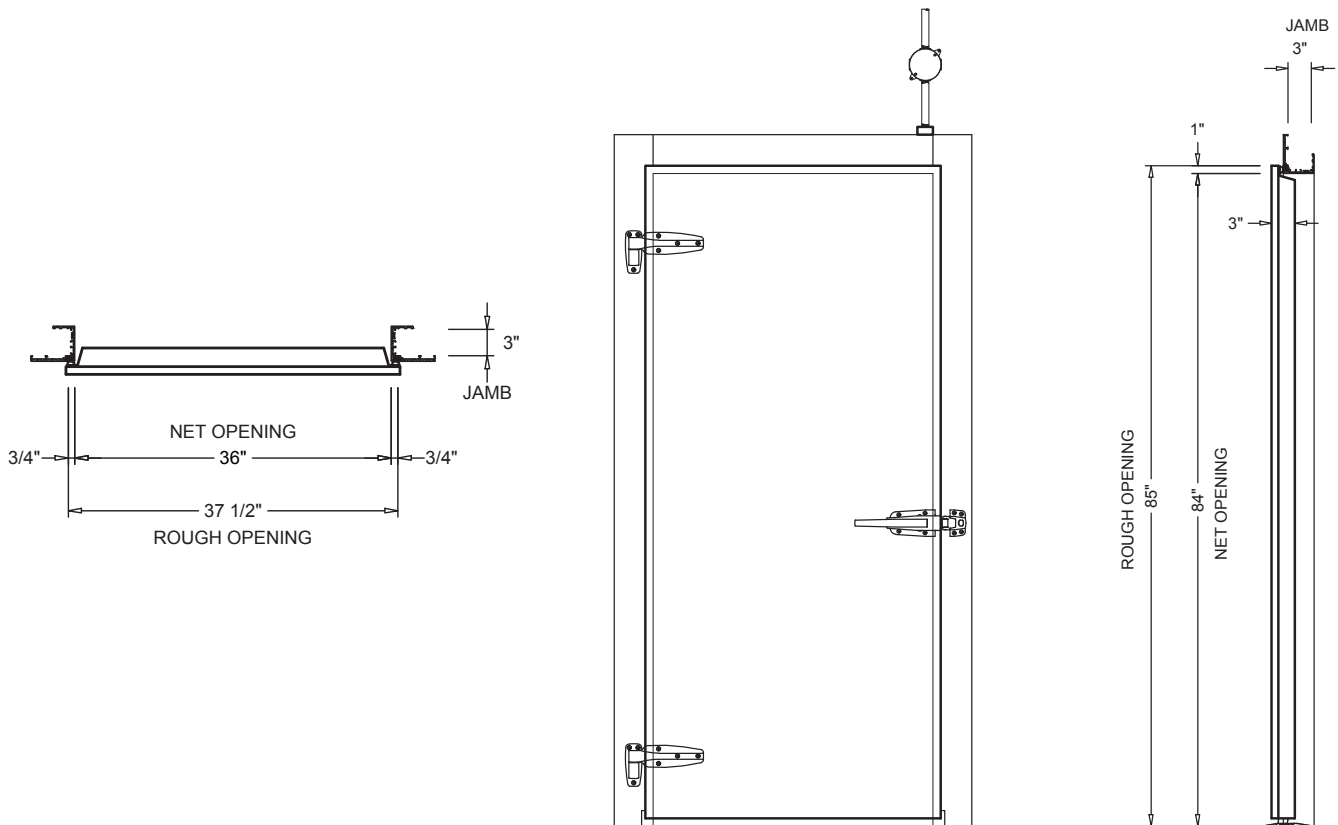



PL-1650-D

BI-PARTITION HINGED DOOR

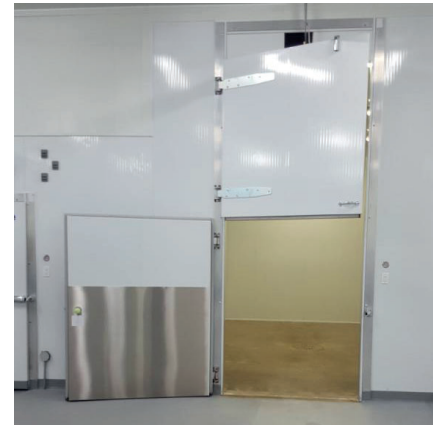

The materials used in the manufacture of hinged doors are sturdy and provide superior sealing. Each door is individually designed and manufactured in-house. From designing to manufacturing, the concern for quality is vital in product development.

In addition to providing good insulation properties and enhanced waterproof seal, the doors are designed to withstand daily activities throughout the years. They are manufactured for the most demanding environments (heavy duty usage, high salinity, moisture and strong chemicals). Norbec considers industry regulations such as health standards, energy standards and building standards throughout the entire process.

ADVANTAGES OF NORBEC HINGED DOORS

- ▶ Highly resistant structure
- ▶ Easy and quick installation
- ▶ Several options available for multiple applications
- ▶ Resistant to corrosion and chemicals
- ▶ Ease of maintenance

DOOR

This flush door is designed so that the outer and inner walls are mechanically assembled to prevent delamination during repeated impacts. Gaskets are easily replaceable in addition of being resistant to grease and detergents. Doors are equipped with galvanized steel reinforcement at the anchor points of the hardware to ensure durability.

FRAME

Constructed from 1/2" thick "L" aluminum profiles, this unique door frame is by far the most robust in the industry. It is provided with a thermal break. The freezer frame is equipped with a heating wire totally integrated in the profile and covered by a molding that facilitates its replacement. The profiled aluminum sill is provided with a double heating wire.

DIMENSIONS

Door thickness : 3", 4" or 5"
Width: 48" to 120"
Height: 72" to 192"

Other dimensions available upon request

HARDWARE

HINGES	HANDLES	INTERIOR PUSH BAR	BOLT SPRING
2 Kason #1245 (for doors under 48") or 2 Kason #1277	Kason #78 brushed chrome	Kason #481 glow-in-the-dark knob	Wilcox #514X2 et #524X0

OPTIONS

- ▶ Protection kick plates
 - 18 or 16 gauge galvanized steel
 - 14,16 or 18 gauge stainless steel # 2B
 - Aluminum tread plate 1/16", 1/8" ou 3/16"
- ▶ ST-1000 independent surface threshold for freezers. Heater wire is covered by a 3/8" thick aluminum plate.
- ▶ RT-1000 independent recessed threshold in the concrete slab
Heater wire is covered by a 3/8" thick aluminum plate
- ▶ "L" shaped threshold for doors without door broom
- ▶ Extension of door jamb into concrete slab for superior strength
- ▶ Windows

Other options available upon request.

INSTALLATION

The frame is designed to be installed in an existing wall. The opening in the wall should be 1 1/2" wider and 1" higher than the clear opening of the door, including clearance for adjustment. The front of the frame must be bolted through the wall with carriage bolts that join the rear of the frame. The frame mounting holes are pre-drilled at the factory. Bolts, nuts, washers and finish caps are supplied with the door. Reinforcement angles must be added inside the left and right sides of the door frame.

TECHNICAL DETAILS

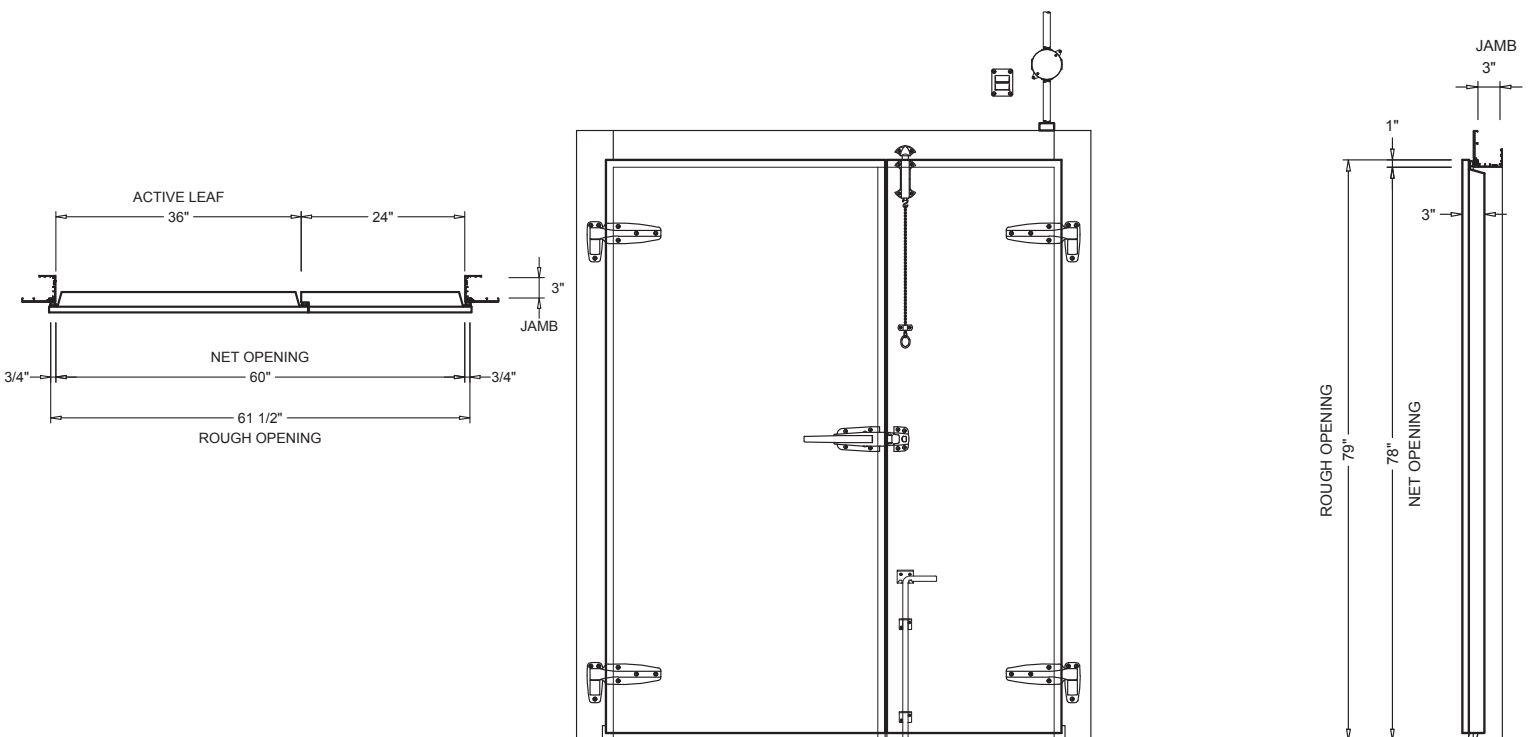



BL-1650

HINGED DOOR FOR BLAST COOLER OR FREEZER

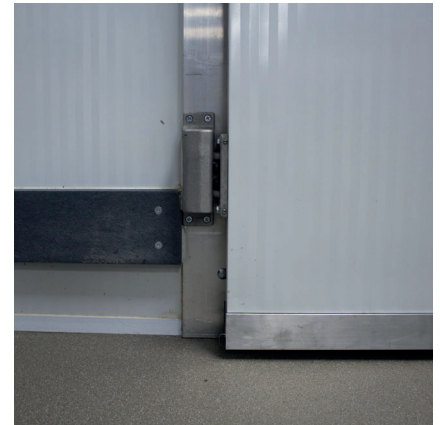

The materials used in the manufacture of hinged doors for blast freezer or cooler are strong and provide superior sealing. Each door is individually designed and manufactured in-house. From designing to manufacturing, the concern for quality is vital in product development.

In addition to providing good insulation properties and enhanced waterproof seal, the doors are designed to withstand very low and high temperatures variations environment. They are manufactured for the most demanding environments (heavy duty usage, high salinity, moisture and strong chemicals). Norbec considers industry regulations such as health standards, energy standards and building standards throughout the entire process.

ADVANTAGES OF NORBEC HINGED DOORS

- ▶ Highly resistant structure
- ▶ Easy and quick installation
- ▶ Resistant to corrosion and chemicals
- ▶ Ease of maintenance

DOOR

This full overlap door is designed to ensure a superior insulation and seal. The outer and inner walls are mechanically assembled to prevent delamination during repeated impacts. Gaskets are easily replaceable in addition of being resistant to grease and detergents. Doors are equipped with galvanized steel reinforcement at the anchor points of the hardware to ensure maximum durability.

FRAME

Constructed from 1/2" thick "L" aluminum profiles, this unique door frame is by far the most robust in the industry. It is provided with a thermal break. The frame is equipped with a heating wire totally integrated in the profile and covered by a molding that facilitates its replacement. The profiled aluminum sill is provided with a double heating wire.

DIMENSIONS

Door thickness: 4" or 5"
Width: 36" to 72"
Height: 72" to 120"

Other dimensions available upon request

HARDWARE

HINGES	DOOR CLOSER AND LATCH
2 Kason #1398, enameled zink (3 hinges if more than 84")	Kason #199 for overlapping blast door

OPTIONAL ACCESSORIES

- ▶ Protection kick-plates
 - 18 or 16 gauge galvanized steel
 - 14, 16 or 18 gauge stainless steel # 2B
 - Aluminum tread plate 1/16", 1/8" ou 3/16"
- ▶ ST-1000 independent surface threshold for freezers. Heater wire is covered by a 3/8" thick aluminum plate.
- ▶ RT-1000 independent recessed threshold in the concrete slab
 - Heater wire is covered by a 3/8" thick aluminum plate
 - "L" shaped threshold for doors without door broom
 - Extension of door jamb into concrete slab for superior strength

Other options available upon request.

INSTALLATION

The frame is designed to be installed in an existing wall. The opening in the wall should be 1 1/2" wider and 1" higher than the clear opening of the door, including clearance for adjustment. The front of the frame must be bolted through the wall with carriage bolts that join the rear of the frame. The frame mounting holes are pre-drilled at the factory. Bolts, nuts, washers and finish caps are supplied with the door. Reinforcement angles must be added inside the left and right sides of the door frame.

TECHNICAL DETAILS

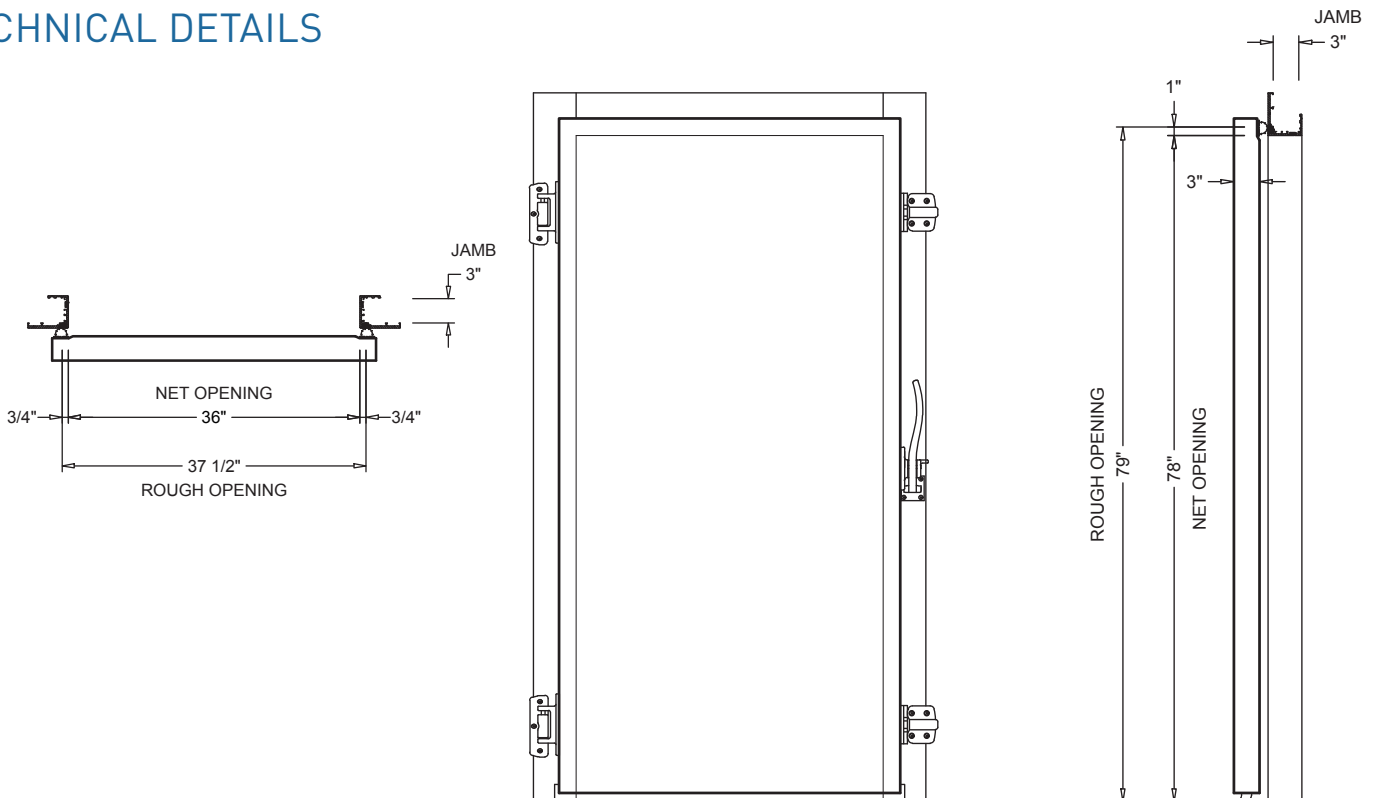



PP-130

HINGED DOOR



The materials used in the manufacture of hinged doors are sturdy and provide superior sealing. Each door is individually designed and manufactured in-house. From designing to manufacturing, the concern for quality is vital in product development.

In addition to providing good insulation properties and enhanced waterproof seal, the doors are designed to withstand daily activities throughout the years. They are manufactured for the most demanding environments (heavy duty usage, high salinity, moisture and strong chemicals). Norbec considers industry regulations such as health standards, energy standards and building standards throughout the entire process.

ADVANTAGES OF NORBEC HINGED DOORS

- › Highly resistant structure
- › Easy and quick installation
- › Several options available for multiple applications
- › Resistant to corrosion and chemicals.
- › Easy maintenance

DOOR

This offset door is designed so that the outer and inner walls are mechanically assembled to prevent delamination during repeated impacts. Polyvinyl seals are easily replaceable. A single leaf door can be manufactured up to 36" wide.

FRAME

The door is mounted directly to a 47" wide camlock panel with a 1/4" aluminum jamb that incorporates a thermal break under the seal and a groove for easily accessible heating wire. All the pre-spun components in the frame are grouped together at a single point of connection.

DIMENSIONS

Door thickness: 3", 4" or 5"
Width: 24" to 42"
Height: 72" to 120"

Other dimensions available upon request

HARDWARE

HINGES	HANDLES	PRESSURE RELIEF VALVE FOR FREEZER	PREWIRED PILOT SWITCH	DIAL THERMOMETER
2 spring loaded hinges Kason #1245 (3 hinges if more than 84")	Kason #78	Kason #1825		

OPTIONAL ACCESSORIES

- Nylon spring loaded hinges Kason #1248
- Magnetic joints with Heavy duty lever locking handle Kason #1236
- Spring action door closer Kason #1095 or hydraulic door closer #1092 (for magnetic gasket joints only)
- Foot treadle (for magnetic gasket joints only)
- Windows
- Protection kick plates
 - 18 or 16 gauge galvanized steel
 - 14,16 or 18 gauge stainless steel # 2B
 - Aluminum tread plate 1/16", 1/8" or 3/16"
- Panic bar with pull handle

Other options available upon request.

INSTALLATION

The panels are fixed with cam-lock fasteners and the frame is integrated into a panel. A reinforcing angle will be added on each side of the frame to the floor, on the inside.

TECHNICAL DETAILS

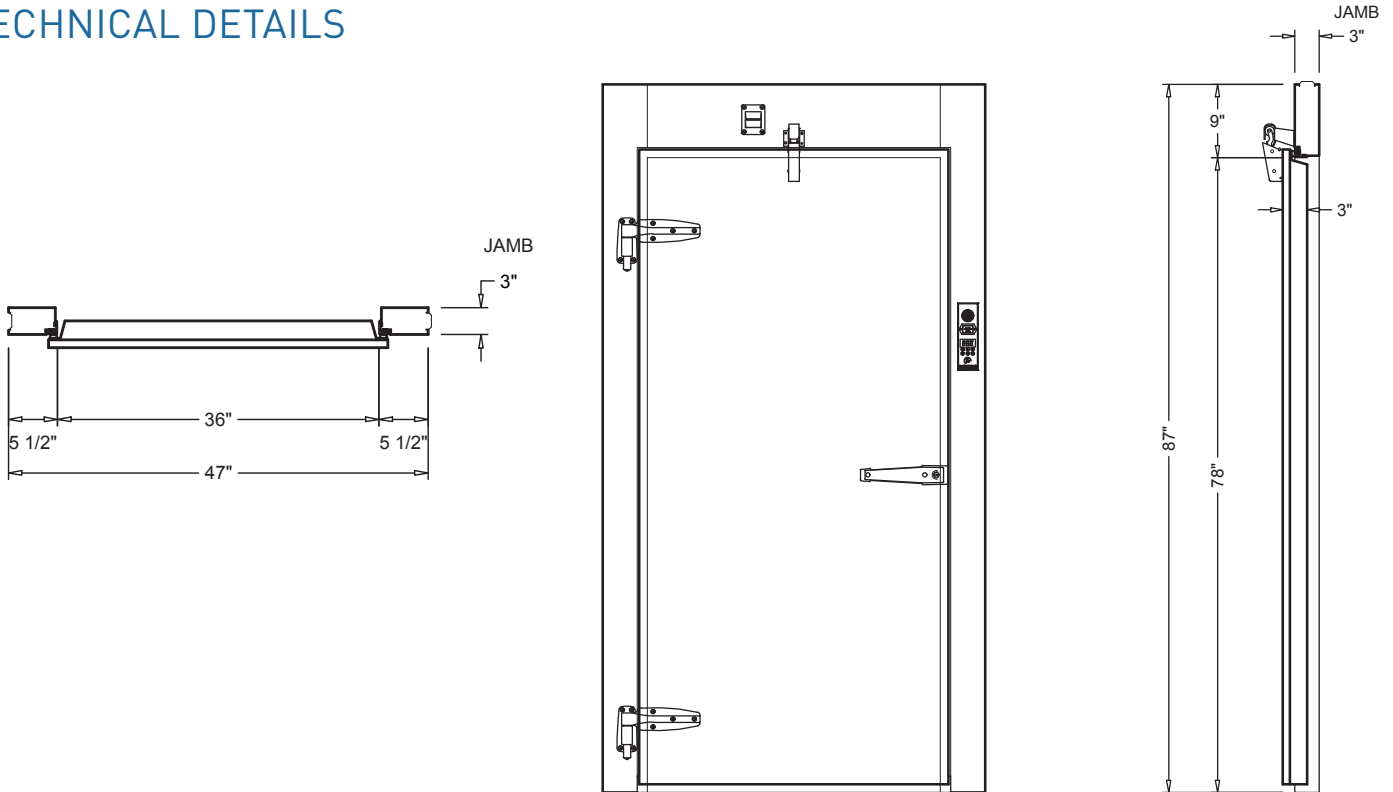



PP-335

HINGED DOOR



The materials used in the manufacture of hinged doors are sturdy and provide superior sealing. Each door is individually designed and manufactured in-house. From designing to manufacturing, the concern for quality is vital in product development.

In addition to providing good insulation properties and enhanced waterproof seal, the doors are designed to withstand daily activities throughout the years. They are manufactured for the most demanding environments (heavy duty usage, high salinity, moisture and strong chemicals). Norbec considers industry regulations such as health standards, energy standards and building standards throughout the entire process.

ADVANTAGES OF NORBEC HINGED DOORS

- › Highly resistant structure
- › Easy and quick installation
- › Several options available for multiple applications
- › Resistant to corrosion and chemicals
- › Easy maintenance

DOOR

This flush door is designed so that the outer and inner walls are mechanically assembled to prevent delamination during repeated impacts. Polyvinyl seals are easily replaceable. A single leaf door can be manufactured up to 36" wide.

FRAME

The door is mounted directly to a 47" wide cam-lock panel with a 1/4" aluminum jamb that incorporates a thermal break under the seal and a groove for easily accessible heating wire. All the pre-spun components in the frame are grouped together at a single point of connection.

DIMENSIONS

Door thickness: 3", 4" or 5"
Width: 24" to 42"
Height: 72" to 120"

Other dimensions available upon request

HARDWARE

HINGES	HANDLES	PRESSURE RELIEF VALVE FOR FREEZER	SPRING LOADED DOOR CLOSER	PREWIRED PILOT SWITCH	DIAL THERMOMETER
2 spring loaded hinges Kason #1245 (3 hinges if more than 84")	Kason #1229	Kason #1825	Kason #1095		

OPTIONAL ACCESSORIES

- ▶ Nylon spring loaded hinges Kason #1245
- ▶ Heavy duty lever locking handle Kason #1236
- ▶ Spring action door closer Kason #1095
- ▶ Foot treadle (for magnetic gasket joints only)
- ▶ Windows
- ▶ Protection kick plates
 - 18 or 16 gauge galvanized steel
 - 14,16 or 18 gauge stainless steel # 2B
 - Aluminum tread plate 1/16", 1/8" or 3/16"
- ▶ Panic bar with pull handle

Other options available upon request.

INSTALLATION

The panels are fixed with camlock fasteners and the frame is integrated into a panel. A reinforcing angle will be added on each side of the frame to the floor, on the inside.

TECHNICAL DETAILS

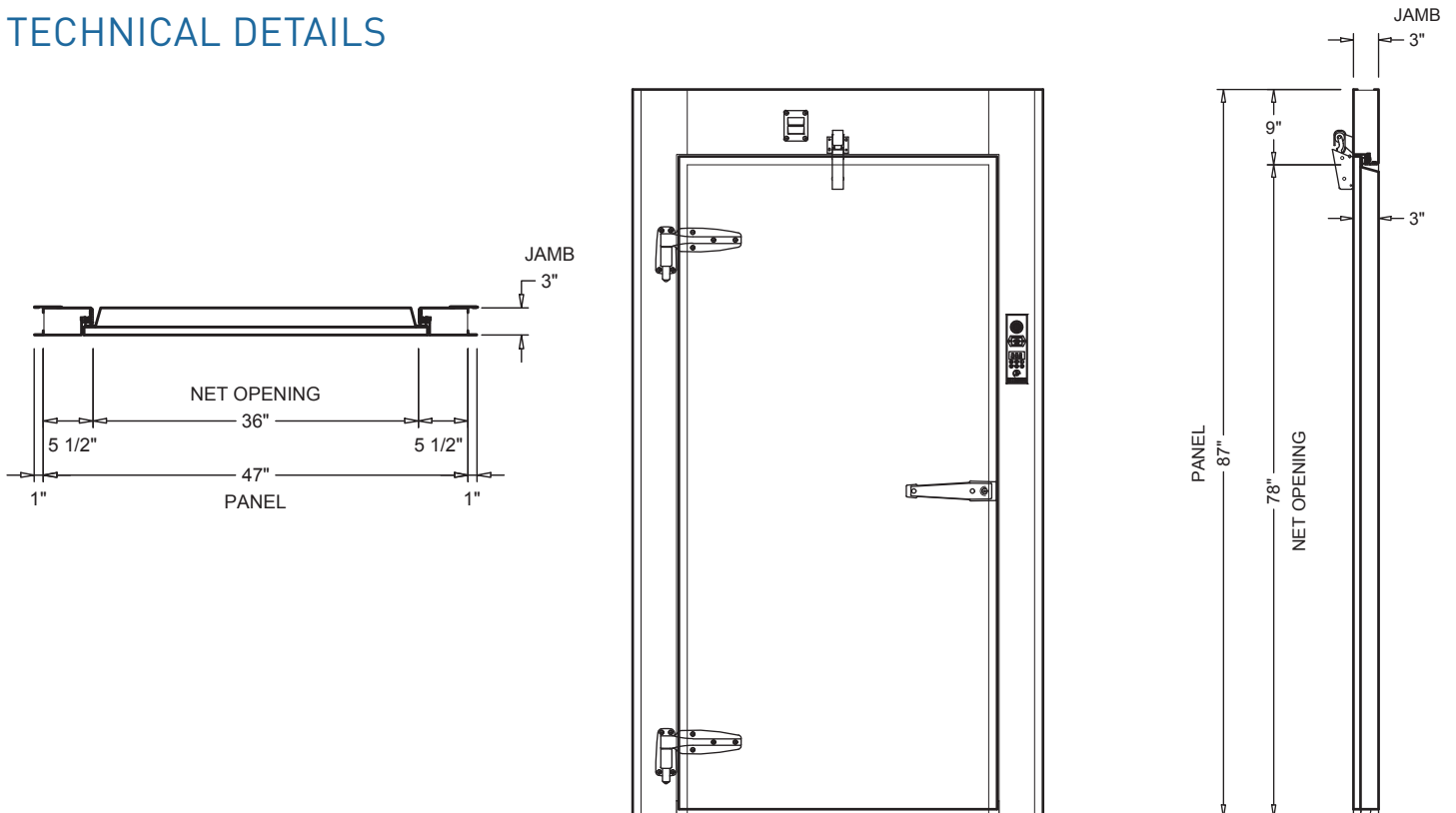



PP-330

HINGED DOOR



The materials used in the manufacture of hinged doors are sturdy and provide superior sealing. Each door is individually designed and manufactured in-house. From designing to manufacturing, the concern for quality is vital in product development.

In addition to providing good insulation properties and enhanced waterproof seal, the doors are designed to withstand daily activities throughout the years. They are manufactured for the most demanding environments (heavy duty usage, high salinity, moisture and strong chemicals). Norbec considers industry regulations such as health standards, energy standards and building standards throughout the entire process.

ADVANTAGES OF NORBEC HINGED DOORS

- ▶ Highly resistant structure
- ▶ Easy and quick installation
- ▶ Several options available for multiple applications
- ▶ Resistant to corrosion and chemicals
- ▶ Easy maintenance

DOOR

This offset type door is designed so that the outer and inner walls are mechanically assembled to prevent delamination during repeated impacts. Polyvinyl seals are easily replaceable. A single leaf door can be manufactured up to 36" wide.

FRAME

The door is mounted directly to a 47" wide cam-lock panel with a 1/4" aluminum jamb that incorporates a thermal break under the seal and a groove for easily accessible heating wire. All the pre-spun components in the frame are grouped together at a single point of connection.

DIMENSIONS

Door thickness: 3", 4" or 5"
Width: 24" to 42"
Height: 72" to 120"

Other dimensions available upon request

HARDWARE

HINGES	HANDLES	PRESSURE RELIEF VALVE FOR FREEZER	SPRING LOADED DOOR CLOSER	PREWIRED PILOT SWITCH	DIAL THERMOMETER
2 spring loaded hinges Kason #1245 (3 hinges if more than 84")	Kason #1229	Kason #1825	Kason #1095		

OPTIONAL ACCESSORIES

- ▶ Nylon spring loaded hinges Kason #1245
- ▶ Heavy duty lever locking handle Kason #1236
- ▶ Spring action door closer Kason #1095
- ▶ Foot treadle
- ▶ Windows
- ▶ Protection kick plates
 - 18 or 16 gauge galvanized steel
 - 14,16 or 18 gauge stainless steel # 2B
 - Aluminum threadplate 1/16", 1/8" ou 3/16"
- ▶ Panic bar with pull handle

Other options available upon request.

INSTALLATION

The panels are fixed with cam-lock fasteners and the frame is integrated into a panel. A reinforcing angle will be added on each side of the frame to the floor, on the inside.

TECHNICAL DETAILS

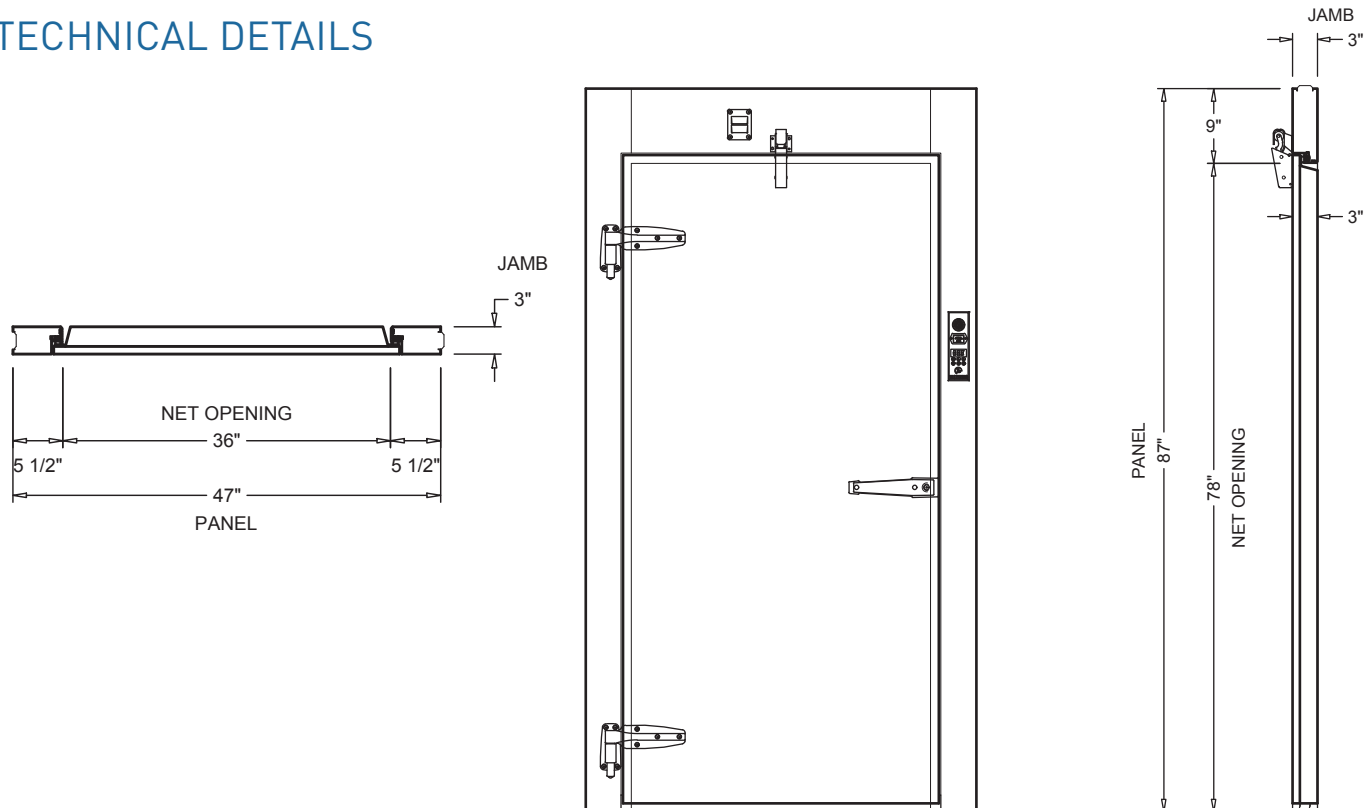



SP-130

HINGED SERVICE DOOR



The materials used in the manufacture of hinged doors are sturdy and provide superior sealing. Each door is individually designed and manufactured in-house. From designing to manufacturing, the concern for quality is vital in product development.

In addition to providing good insulation properties and enhanced waterproof seal, the doors are designed to withstand daily activities throughout the years. They are manufactured for the most demanding environments (heavy duty usage, high salinity, moisture and strong chemicals). Norbec considers industry regulations such as health standards, energy standards and building standards throughout the entire process.

ADVANTAGES OF NORBEC HINGED DOORS

- ▶ Highly resistant structure
- ▶ Easy and quick installation
- ▶ Several options available for multiple applications
- ▶ Resistant to corrosion and chemicals

DOOR

These doors are used to access rapidly small quantities of produce in restaurants or grocery stores as well as for the refill of crates on conveyor belts. Shelving units can be added in order to facilitate the advantages mentioned above. The doors are 1 5/8" in thickness and accompanied by joints made Polyvinyle, resistant to oils and other liquids. To be noted, panels can have one or two doors.

FRAME

The door is mounted directly to a 47" wide cam-lock panel with a 1/4" aluminum jamb that incorporates a thermal break under the seal and a groove for easily accessible heating wire. All the pre-spun components in the frame are grouped together at a single point of connection.

DIMENSIONS

Door Thickness 3", 4" or 5"
Width: 18", 24", 30" or 36"
Height: 18", 24", 36", 48" or 60"

Other dimensions available upon request.

HARDWARE

HINGES	HANDLES
2 Kason #214 chrome	Kason #174 chrome with lock

OPTIONAL ACCESSORIES

► Variety of colours and finishes available, refer to norbec's colour chart for camlock panels.

INSTALLATION

The doors are integrated into the panel during the manufacturing process and therefore, simply need to be hooked with other camlock panels.

TECHNICAL DETAILS

